



**WASTE HAS NEVER
BEEN THIS CLEAN.**

TRANSFORM ORGANIC WASTE INTO RENEWABLE ENERGY WITH FITEC.

We live in a time when there's never been more waste or a greater need for clean energy.

That's why Fitec provides advanced equipment and support to divert organic waste from landfills and transform it into biogas for use in local energy grids as renewable natural gas or electricity.

We are committed to providing robust, holistic, high-performance biogas solutions for our clients and partners.

With Fitec, it's not just biogas, it's Precision Biogas™.



Holding tanks at ZooShare biogas plant in Toronto, Ontario

THIS IS PRECISION BIOGAS™

All Fitec equipment is designed to be modular and scalable to ensure a custom solution tailored to your specific needs.

Our holistic systems outperform the industry's average competitor in efficiency and reliability.

96% Organics
Recovery Rate

Sustainable

Our system utilizes a two-stage organics cleaning process: a primary coarse separation followed by a secondary fine cleaning step. This allows us to recover more than 96% of the contaminated food waste's energy.

90% Plant
Efficiency

Efficient

With industry-leading efficiency, our average biogas plant only requires 10% of its energy output to operate, and often, the need for process water is sometimes completely eliminated as our systems handle a high level of total solids.

99% Average
Up-Time

Reliable

Our operations and dependable technology maximize availability, increasing your ability to take organic wastes when others can't.

30+ Years
10+ Countries

Experienced

With three decades of biogas expertise and successful projects globally, Fitec has the experience to find solutions that will work for you.

SOLUTIONS FOR A VARIETY OF MARKETS

We're a Canadian company providing robust and reliable biogas solutions to a variety of markets in North America: farmers, municipalities, project developers, engineering and consulting firms, waste management companies, and more.

Fitec knows that every project and opportunity is different, no matter what sector you're in. That's why our team is available to assess and identify the best solution for your unique needs.

Farmers



Simple and flexible systems that process a wide range of feedstocks.

Municipalities



Unique processes that help achieve waste diversion targets.

Project Developers



Support to optimize capital expenditures and keep operating costs low.

Select Clients & Partners

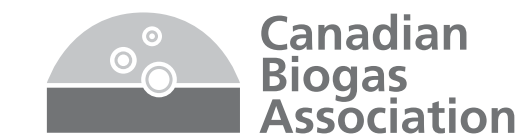

MEET OUR CEO, TOM.



Tom Ferencevic
CEO & Environmental
Scientist

“WE BUILD BIOGAS FACILITIES THAT LAST, AND WE HAVE RELATIONSHIPS WITH OUR CLIENTS THAT LAST.”

Our Commitment

Fighting climate change by closing the loop in organic waste ecosystems

Our Story

Tom Ferencevic is an environmental scientist and CEO of Fitec. When Tom first learned about biogas technology, he was amazed. He saw a need and an opportunity to use his knowledge of science and agriculture to develop this emerging renewable energy industry in North America.

In building Fitec’s biogas systems, Tom searched for the best equipment with innovative engineering and quality craftsmanship. In 2007, he joined forces with Finsterwalder Umwelttechnik, a German engineering company with decades of biogas expertise. Together, they’re building trusting relationships and delivering Precision Biogas™ to those who want to interrupt the waste stream, capture the lost value of our refuse, and create renewable energy out of thin air.

HOLISTIC BIOGAS SOLUTIONS THAT JUST WORK

Fitec's comprehensive approach provides both Products & Equipment and Services & Consulting.

Our technologies and process designs are trusted throughout the world, and our expert operations support and consulting services are available when you need them.



Products & Equipment

Our modular and automated biogas systems provide minimal downtime, maximum flexibility and efficiencies, and ease of scalability.



Services & Consulting

We look at systems from a long-term operational and service standpoint, and are well-equipped to help you achieve your biogas performance goals.



Escarpment Renewables biogas plant in Grimsby, Ontario

INSIDE OUR BIOGAS PROCESS

From receiving and conditioning of your organic waste to the digestion and fermentation cycles that produce usable biogas and digestate, Fitec can handle the process, from end to end.

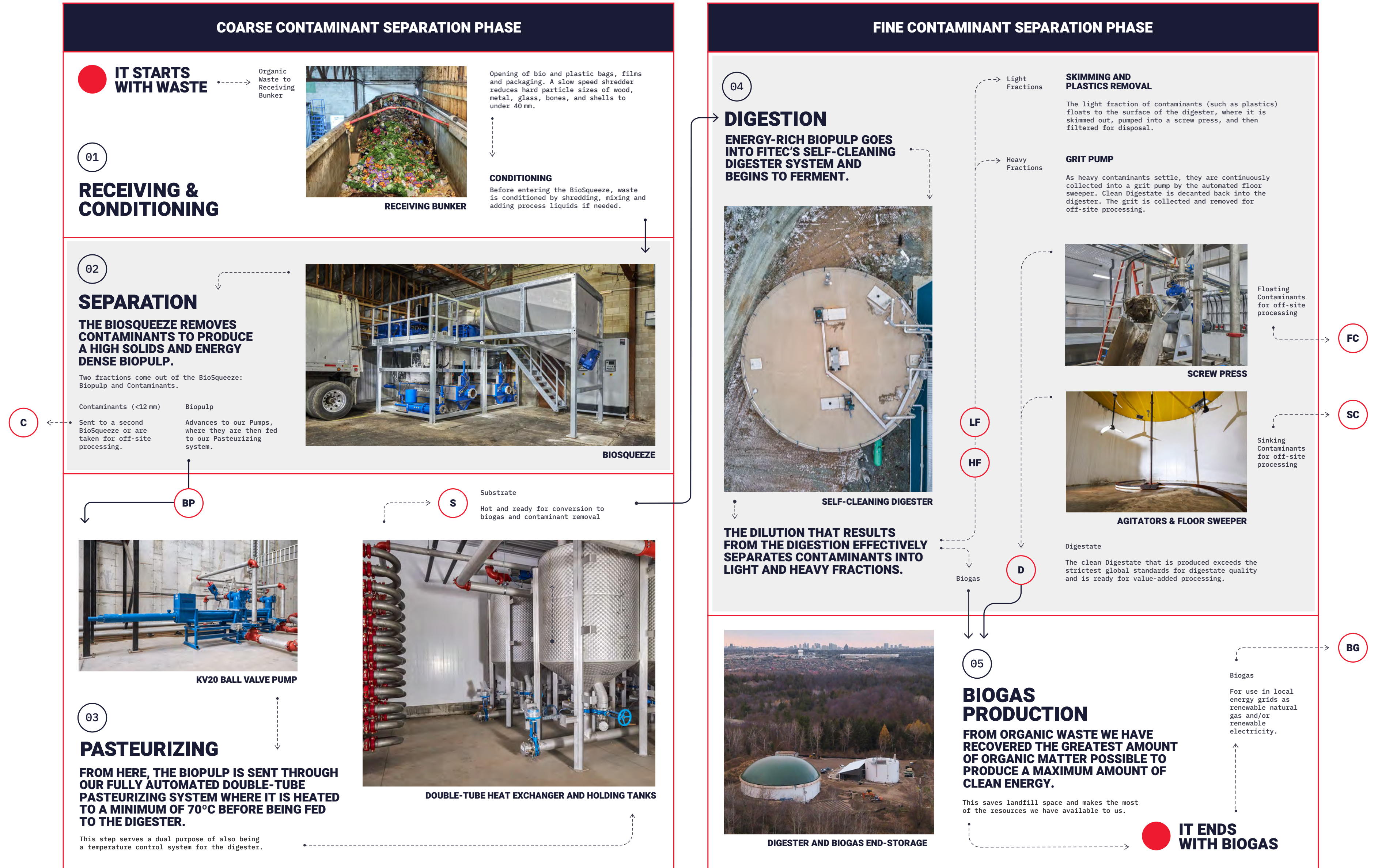

WORLD-CLASS ENGINEERING

Fitec biogas systems are resource-efficient and automated to provide minimal downtime and maximum flexibility. Our equipment features the best German engineering, built in partnership with Finsterwalder Umwelttechnik.



Screw Press squeezing out floating contaminants

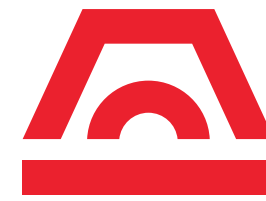

Products & Equipment

Depackaging and contaminant separation

We utilize a powerful and effective hydraulically operated press system. The BioSqueeze 200 performs precise separation of waste into digestible and non-digestible fractions.

Pasteurizing viscous and highly abrasive organics

Our system can pasteurize organics with a high total solids content, allowing operators more feedstock flexibility and producing a more energy dense biopulp.

In-vessel plastics separation and removal

The skimming system consists of a proprietary skimming pump and a screw press that continuously discharges plastics from the digester.

In-vessel grit separation and removal

A rotating floor sweeper removes grit continuously from the digester, preventing the accumulation of contaminants. This system has an impressive record of operating for 15 years without in-vessel mechanical stoppage.

Instantaneous digester health monitoring

Our bicarbonate analyzer allows operators to maximize their biogas production by monitoring feeding capacity levels, preventing overfeeding and avoiding system crashes.

+ more...

Fitec provides the systems and equipment to meet your project's needs. Get in touch to learn more about our products.

BIOSQUEEZE 200

DEPACKAGING & CONTAMINANT SEPARATION

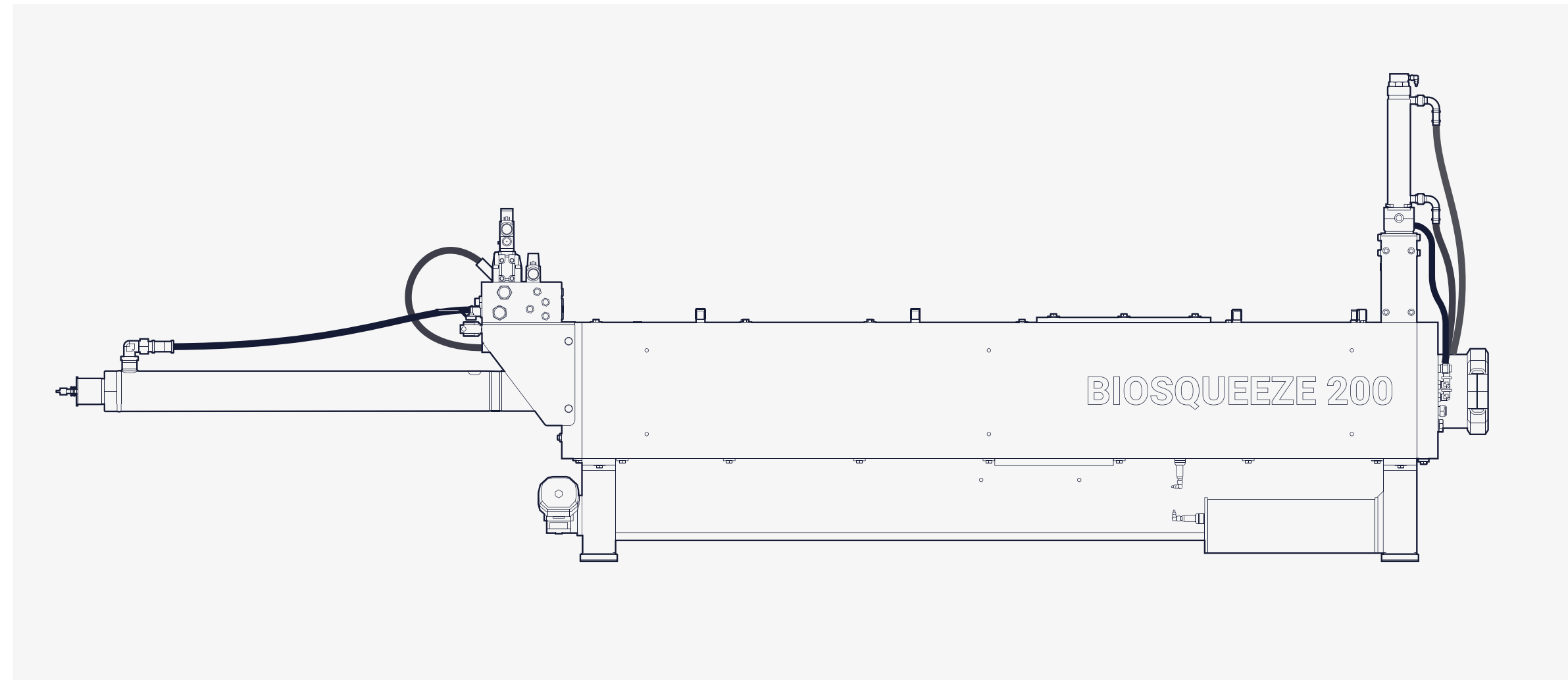

BioSqueeze separation press installed at Davidson Environmental in St. Catharines, Ontario

The BioSqueeze 200, a signature piece of Fitec equipment, is a hydraulically operated press that separates waste into digestible and non-digestible fractions with a high degree of efficiency and reliability.

- » Capable of processing packaged and expired foods, and food waste from private households and restaurants, often without the need for additional liquids.
- » Produces a high-solids, energy-dense biopulp that is ready for pasteurization or digestion without any further processing.

TECHNICAL SPECIFICATIONS

- » Hard particles: sizes up to \varnothing 200 mm (7.8 inches)
- » Pressing power: 40 bar (580 psi)
- » Power demand: max. 15 kW (20 hp)
- » Dimensions: (L x H) 4000 mm (13 ft) x 2000 mm (6.5 ft)
- » Weight: ca. 1700 kg (3750 lbs)

8 m³/h Input Rate
(30 US gallons per minute)

25% Total Solids Content

SELF-CLEANING DIGESTER

AUTOMATED SEDIMENT & FLOATING CONTAMINANTS REMOVAL

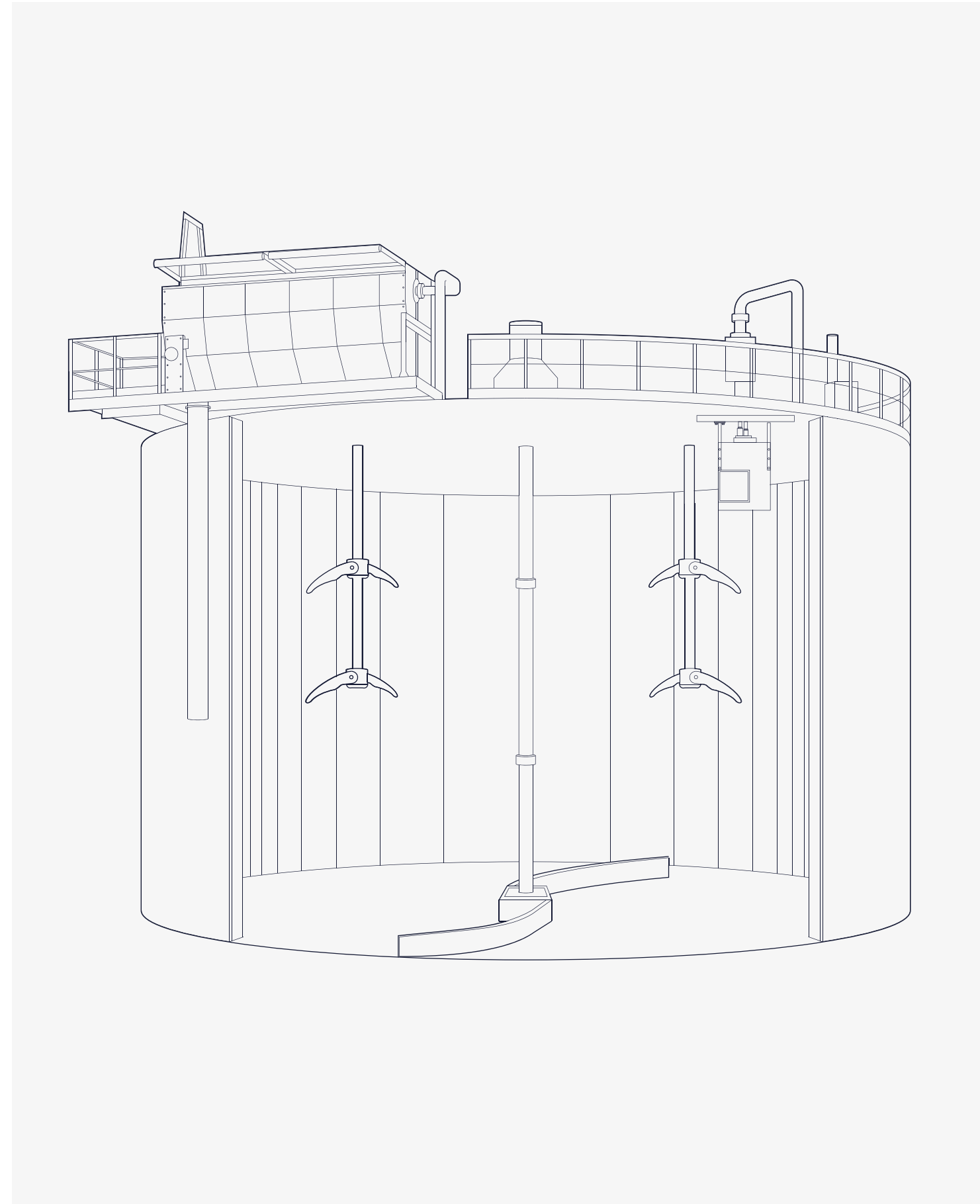

Self-Cleaning Digester at ZooShare biogas plant, Toronto, Ontario



Agitator and Floor Sweeper inside ZooShare's Self-Cleaning Digester

In use at over 15 different biogas plants, the Fitec Self-Cleaning Digester prevents the build-up of contaminants in digester tanks, allowing for long-term, uninterrupted plant operation to maximize revenue. It produces digestate that exceeds the strictest global quality standards for residual contaminants, and can be land-applied or used in fertilizer manufacturing.

- » Floating contaminants such as plastics are removed from the digester's surface using a proprietary skimmer and a screw press system.
- » A mechanical floor sweeper, grit removal pump, and grit separator continuously collect and discharge sinking contaminants from the digester floor.

TECHNICAL SPECIFICATIONS

- » Can be retrofitted into digesters measuring up to 18 m (60 ft) in diameter and 20 m (65 ft) in height if there is no pre-existing central column.
- » Scalable modular system can be designed for small operations of 15,000 tonnes to large operations of 100,000 tonnes of food waste per year.

>99% Average Up-Time

Clean+ Digestate Produced Exceeds Global Standards

FIRST-CLASS SERVICE

As a biogas operator himself, our CEO Tom has developed a complete program of services to support our clients and partners. Fitec looks at systems from an operational standpoint, and is well-equipped to understand your needs.



CEO Tom Ferencevic providing customer support during a biogas plant installation



Services & Consulting

Custom trace element formulation, manufacturing and supply

Anaerobic digestion processes rely on the health of their biological systems. Providing trace elements improves a digester's performance.

Biological health monitoring

Facilities that are currently underperforming can maximize revenues by increasing feedstock process capacity and biogas production.

Biological system simulations

Our proprietary BIOTIP AD software creates a comprehensive simulation of your entire biogas process in real time, providing valuable data to improve your system's performance.

Feedstock analysis

Fitec's feedstock analysis identifies waste combinations that offer the most stable, high-volume biogas production to maximize your plant's revenues.

+ more...

Fitec helps biogas plants across North America, and can support your plant regardless of its design and engineering.

Get in touch to learn how Fitec can support your project's needs.

DESIGNED & ENGINEERED BY FITEC

ZOOSHARE

Toronto, Ontario



A renewable energy co-operative in the heart of Canada's largest urban area.

PROJECT DETAILS

- » 17,000 tonnes/yr of commercial and municipal SSO

FITEC SUPPLY

- » Receiving and Pasteurization
- » Automated Self-Cleaning Digester
- » Plant Control System

ESCARPMENT RENEWABLES

Grimsby, Ontario



Retro-fitting an existing biogas plant with key Fitec components gives this facility new capacity for waste and revenue.

PROJECT DETAILS

- » 45,000 tonnes/yr of commercial ICI and municipal SSO

FITEC SUPPLY

- » Agitators
- » KV Ball Valve Pumps
- » Pasteurizing System
- » Automated Digester Plastics Removal
- » Plant Control System Upgrade

DAVIDSON ENVIRONMENTAL

St. Catharines, Ontario



A waste sorting facility with a plug-and-play solution that turns packaged waste into an energy-dense biopulp.

PROJECT DETAILS

- » 15,000 tonnes/yr of municipal SSO

FITEC SUPPLY

- » Auger Feeding System
- » Shredder
- » BioSqueeze Separation Press (BS200)
- » KP10 Gate Valve Transfer Pump
- » Plant Control System

COURTHOUSE HILL FARM

Gore, Nova Scotia



An East Coast dairy farm takes advantage of provincial incentives to help make the shift to cleaner energy.

PROJECT DETAILS

- » 20,000 tonnes/yr of commercial ICI

FITEC SUPPLY

- » Plant Design
- » KV20 Ball Valve Pumps
- » Pasteurizing System
- » Automated Self-Cleaning Digester

COMMITTED TO THE SUCCESS OF OUR PARTNERS



Greg Blois and his son Morgan represent the seventh and eighth generations of family farming on this land, since 1784.



Greg Blois
Courthouse Hill Farm
Gore, Nova Scotia

“WE LIKE THE FACT THAT OUR FITEC DIGESTER IS CONTINUOUSLY BEING CLEANED AND DOESN’T REQUIRE A SHUTDOWN LIKE OTHER DIGESTERS.”

“Fitec designed our plant layout and even helped sourcing the CHP. They continue to provide biological assistance on a regular basis and answer our operational questions as they come up. It’s a pleasure working with Tom and his team.”



THERE'S BIOGAS, AND THEN THERE'S
PRECISION BIOGAS™